

Impressions

Flush Jet Technology



Technical Specifications and
Installers Manual

Impressions

INDEX

Product ListPage 1 & 2

Product Technical Specifications

JAI6PLS1	Body Impressions 25x10.....	Page 3
JAI6PLS1	Directional jet.....	Page 4
JAI6PLS1	Swirl Jet.....	Page 5
BR1080F	Body impressions Mini 19mm.....	Page 6
BR0280F	Body impressions Mini 25x10.....	Page 7
JR070103	Jet impressions Mini.....	Page 8
JAI8PLS1	Body Impressions 25x10.....	Page 9
JAI8PLS1	Adjustable and directional impressions Jet.....	Page 10
SAI1	Suction Elbow impressions 40.....	Page 11
SAI1	Suction Cover impressions.....	Page 12
PB0903	Air Button impressions.....	Page 13
AS080703	Air Control impressions.....	Page 14
VD260703	Diverter Hi Flow wall mount impressions.....	Page 15
VD180703	Diverter Hi Flow Top mount impressions.....	Page 16

Product Installation Instructions

Body impressions 25x10.....	Page 17
Directional Jet.....	Page 18
Swirl Jet.....	Page 19
Body impressions Mini 19mm.....	Page 20
Body impressions Mini 25x10.....	Page 21
Jet impressions Mini.....	Page 22
Body impressions 25x10.....	Page 23
Adjustable and directional impressions jet.....	Page 24
Suction elbow impressions 40.....	Page 25
Suction cover impressions.....	Page 26
Air Button impressions.....	Page 27
Air Control impressions.....	Page 28
Diverter Hi Flow wall mount impressions.....	Page 39
Diverter Hi Flow Top mount impressions.....	Page 30
Installation Tool MT0168.....	Page 31
Jet Removal Tool.....	Page 32
Pipe Fittings, Clamps and Manifolds.....	Page 33
How a Hartford Loop Works.....	Page 34
How a Safeflow Suction Works.....	Page 35
Standards.....	Page 36
Critical Check List.....	Page 37

Impressions

Product List

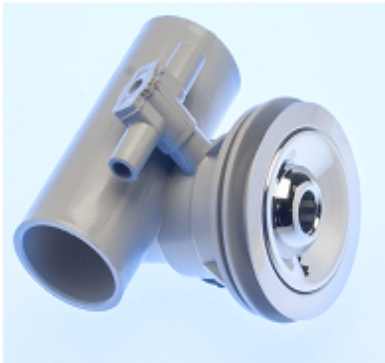

Product: Jet Assembly, 6.46CM, Impressions, Directional Eyeball, 3/8" Spigot X 1" Socket, Straight, Flush

Part Number: JAI6PLS1-XX

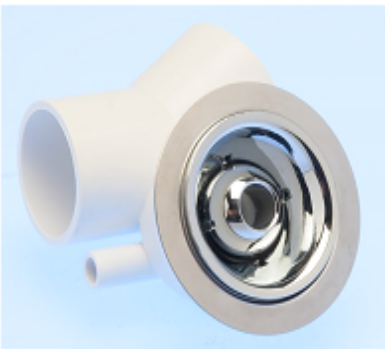

Product: Jet Assembly, 6.46CM, Impressions, Directional Eyeball, 3/8" Spigot X 1" Socket, Vee, Flush

Part Number: JAI6PLV1-XX

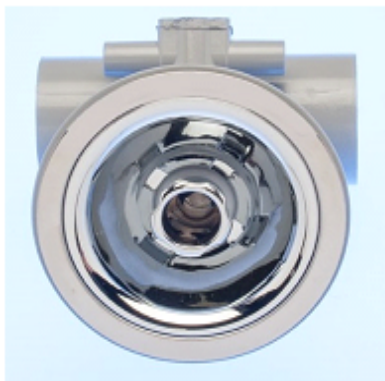

Product: Jet Assembly, 8.16CM, Impressions, Adjustable & Directional Nozzle, 3/8" Spigot X 1" Socket, Straight, Flush

Part Number: JAI8PLS1-XX



Product: Air Injector, 1", Impressions, Salt & Pepper Style, Flush

Part Number: AIISP1-XX



Product: Air Injector, 1", Impressions, Single Hole, Flush

Part Number: AIISG1-XX

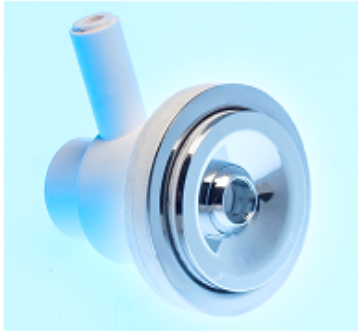

Product: Micro Jet 3 Part Assembly, 4.6CM, Impressions, Directional Eyeball, 3/8" Spigot X 1" Socket, Manifold Venturi, Flush

Part Number: MJ11-XX



Product: Suction Assembly, 9.46CM, Impressions, Flush

Part Number: SAI1-XX



Product: Silent Air Control, Impressions, Flush

Part Number: SACI-XX

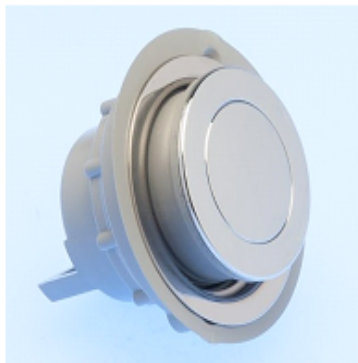

Product: Air Button, Impressions, Flush

Part Number: ABI-XX

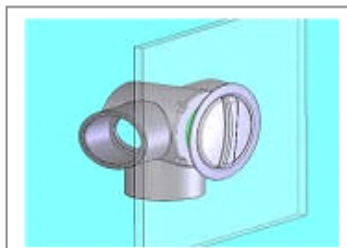

Product: Diverter Hi Flow Wall Mount 25mm Impressions

Part Number: VD260703

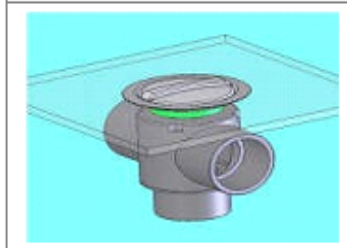

Product: Diverter Hi Flow Top Mount 25mm Impressions

Part Number: VD180703

Impressions

TECHNICAL DATA
SHEETS

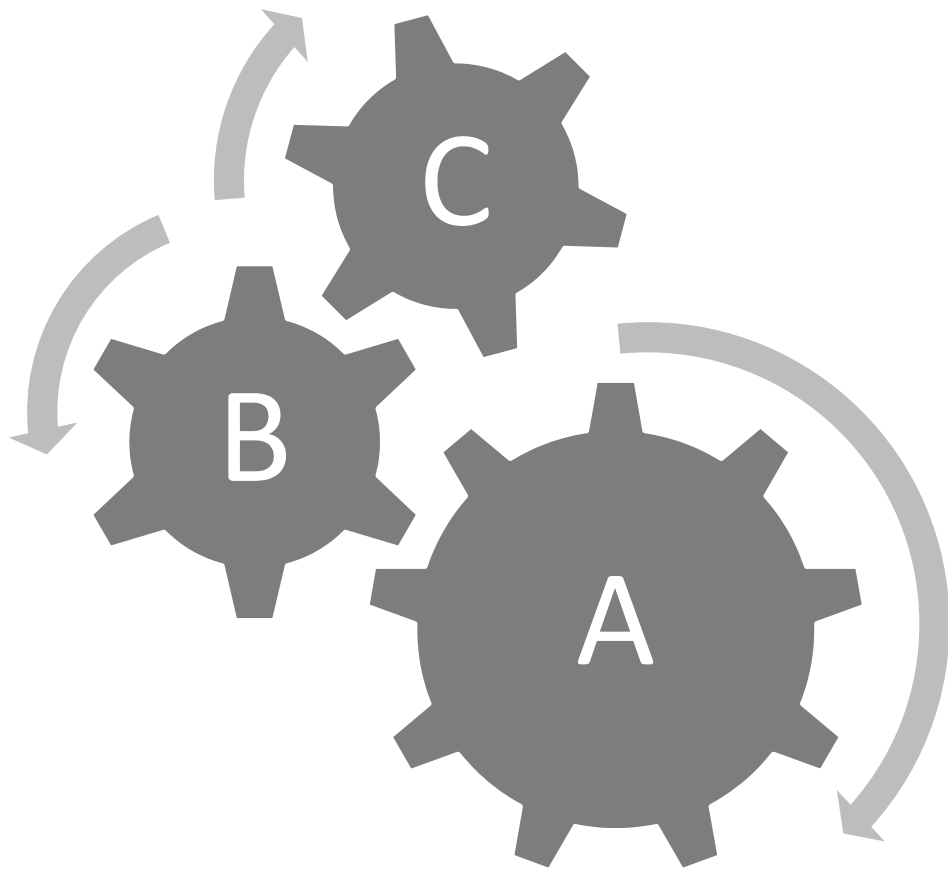

IDENTIFICATION:

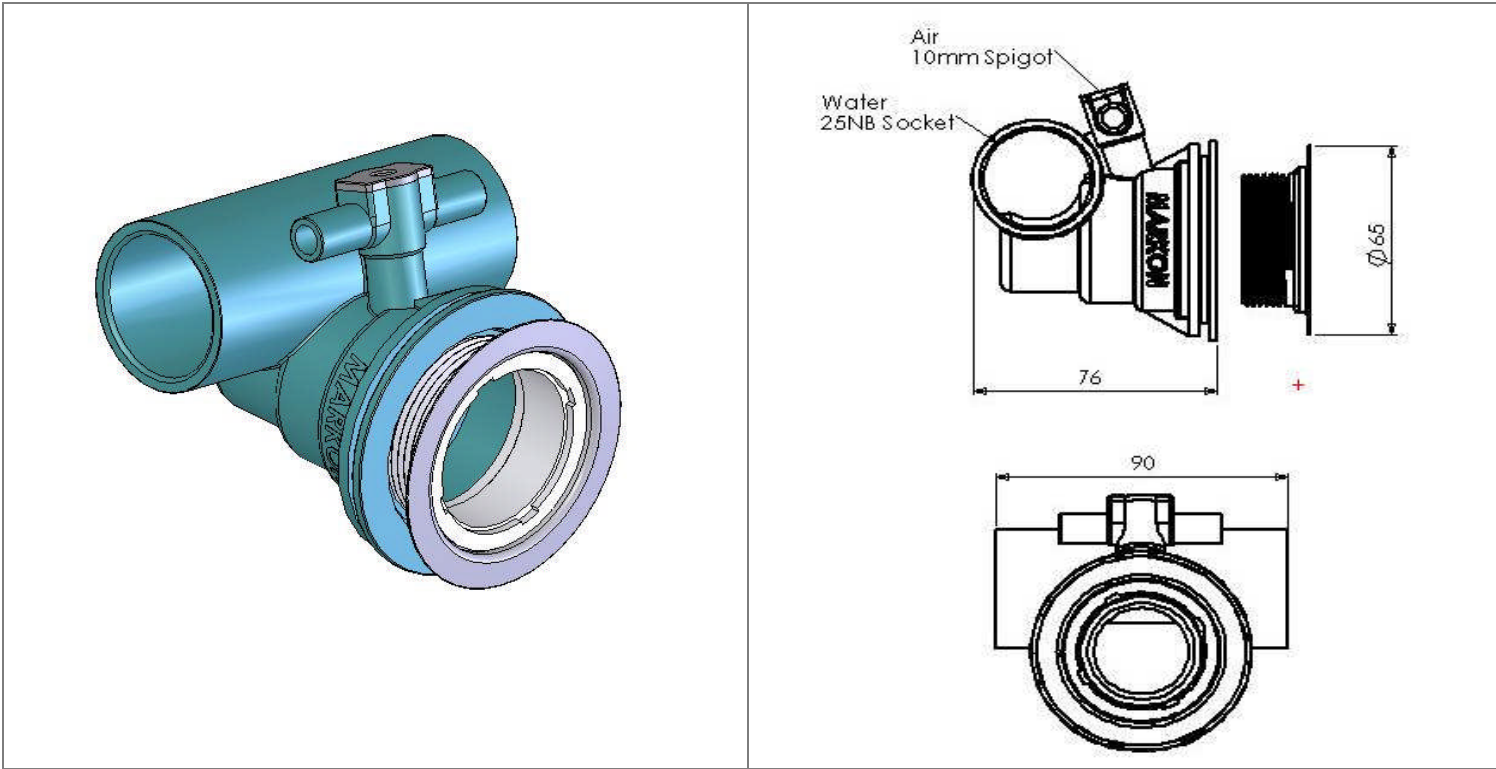

PART NUMBER	JAI6SPL1-XX
PRODUCT NAME	Body Impressions 25x10

DESIGN SPECIFICATIONS

Spa jet body for use with directional and swirl jets

- Non return valve fitted in airline
- Flush mount design
- Patented technology
- Clearance in waterway to use former pipes

TECHNICAL SPECIFICATIONS

WATER LINE CONNECTION	25mm Pipe Socket
AIRLINE CONNECTION	10mm Spigot
MOUNTING HOLE SIZE	50 mm (2inch)
MATERIAL	R12549 Rigid PVC
COLOR	Grey
PACKAGING	

SERVICE INSTRUCTIONS

Due to this product having no moving parts, and as long as the correct installation procedures have been followed there should be no requirement for service in the field

COMPONENT SPECIFICATIONS

Jet Body	PVC
Mounting Flange	Stainless Steel
Retainer	PVC

MATERIAL SAFETY DATA

When installed insure the stainless steel mounting flange sits tight to the bath wall and there are no sharp edges on the stainless steel mounting flange that could cut the user

STANDARDS

Refer to page to manual for a list of standards this product is designed and manufactured to

Always install the product in a manner that minimizes the amount of retained water in the pipe work and fittings

IDENTIFICATION:

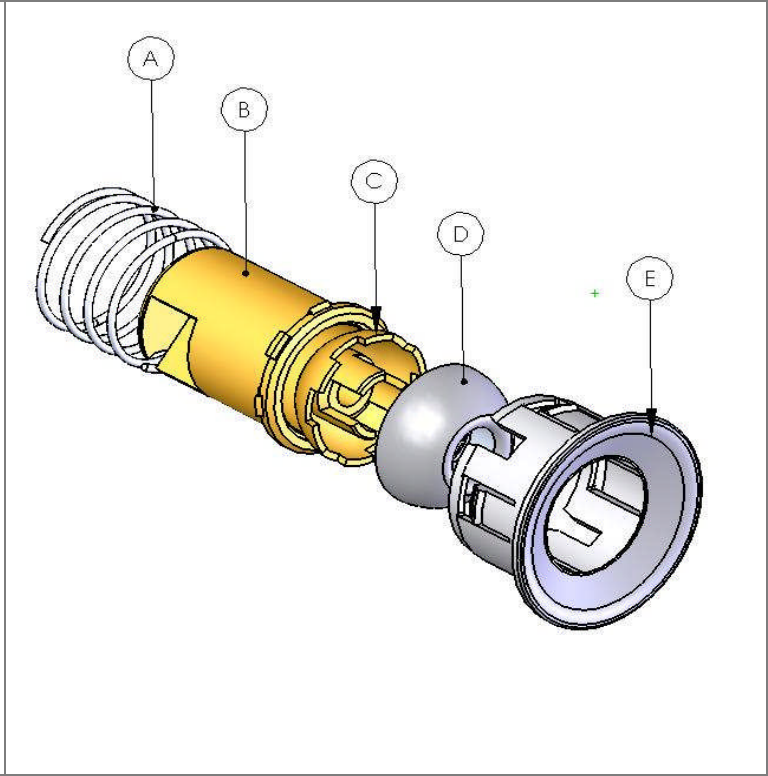
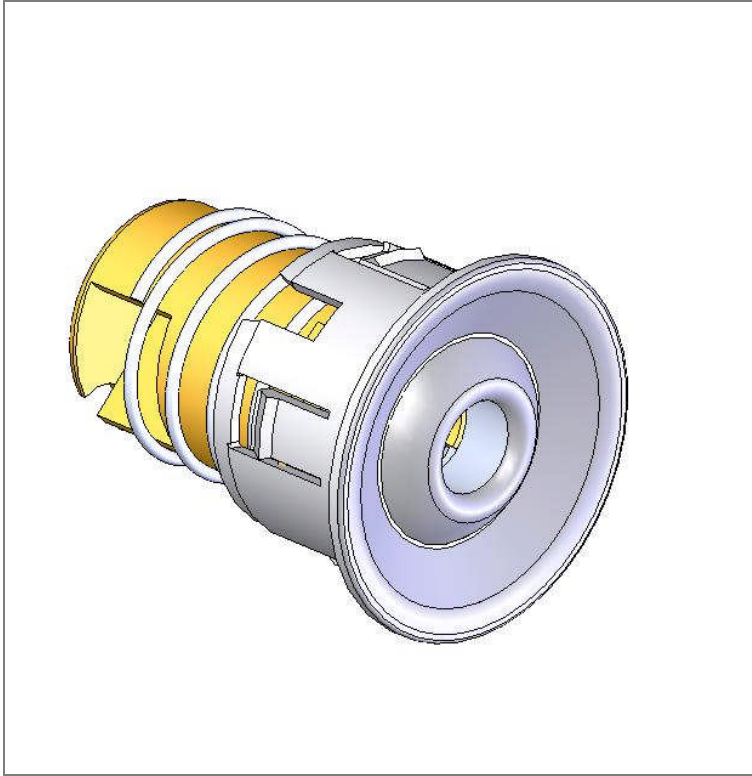

PART NUMBER	JAISPLS1-XX
PRODUCT NAME	directional eyeball jet

DESIGN SPECIFICATIONS

Cartridge type eyeball spa jet for impressions product range
One piece cartridge assembly
Stainless steel spring to create smooth eyeball rotation
Positive lock to engage jet into jet body
Adjustable in direction
Easily removable for cleaning using tool

PRODUCT PART SPECIFICATIONS

ITEM	PART No	NAME	MATERIAL	FINISH
For chrome plate standards and finish refer to "Aesthetics Standard M01.001.002.001"				
PACKAGING			300 per carton	

SERVICE INSTRUCTIONS

This jet is designed to be easily removed as a one piece cartridge for cleaning or service. Using Tool MT0268 depress eyeball, clipping tool under edge of jet face adjacent to the eyeball and pull free.

MATERIAL SAFETY DATA

There are no known hazards with this product. Always insure correct installation procedures have been followed.

FLOW RATE GRAPHS

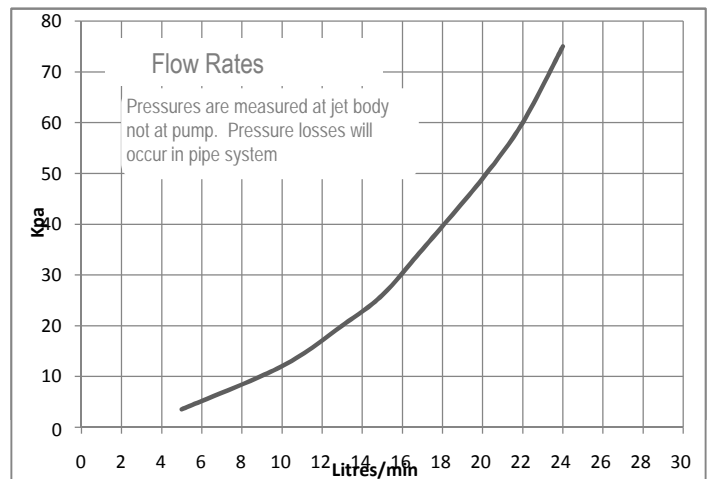

IDENTIFICATION:

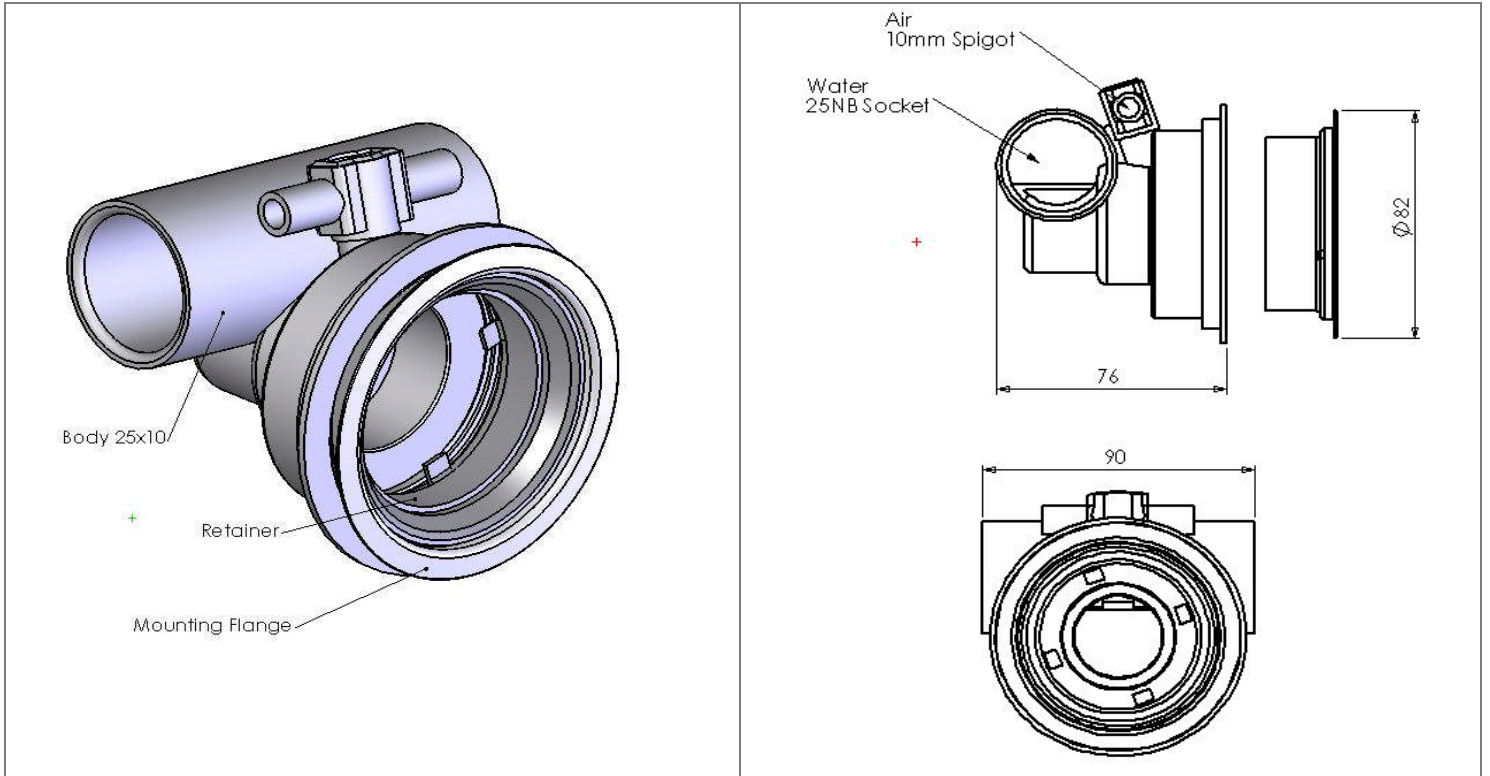

PART NUMBER	JAI8PLS1-XX
PRODUCT NAME	Body c-lenda Maxi 25x10

DESIGN SPECIFICATIONS

Spa jet body for use with JAI8PLS1 jet

Non return valve fitted in airline

Compact body

Anti vortex deflector to maximize jet performance

Flush mount

Patented technology

TECHNICAL SPECIFICATIONS

WATER LINE CONNECTION	25mm Pipe Socket
AIRLINE CONNECTION	10mm Spigot
MOUNTING HOLE SIZE	70mm (2.75 inch)
MATERIAL	R12549 Rigid PVC
COLOR	Grey
PACKAGING	

SERVICE INSTRUCTIONS

Due to this product having no moving parts, and as long as the correct installation procedures have been followed there should be no requirement for service in the field

COMPONENT SPECIFICATIONS

Jet Body	PVC
Mounting Flange	Stainless Steel
Retainer	PVC

MATERIAL SAFETY DATA

When installed insure the stainless steel mounting flange sits tight to the bath wall and there are no sharp edges on the stainless steel mounting flange that could cut the user

STANDARDS

Refer to page 36 of manual for a list of standards this product is designed and manufactured to

Always install the product in a manner that minimizes the amount of retained water in the pipe work and fittings

IDENTIFICATION:

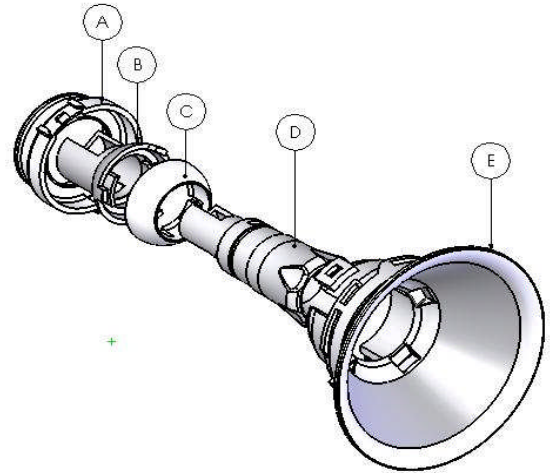
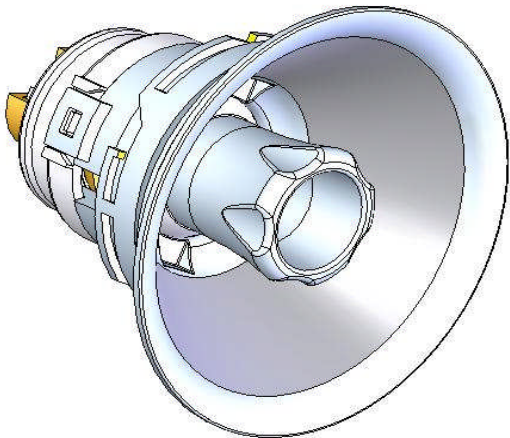

PART NUMBER	JAI8PLS1-XX
PRODUCT NAME	adjustable and directional jet impressions

DESIGN SPECIFICATIONS

JAI8PLS1 jet for impressions product range

- Flush mount design
- Large bore jet
- One piece cartridge
- Adjustable in direction
- Easy twist to adjust flow rate

PRODUCT PART SPECIFICATIONS

ITEM	PART No	NAME	MATERIAL	FINISH
For chrome plate standards and finish refer to "Aesthetics Standard M01.001.002.001"				
PACKAGING				

SERVICE INSTRUCTIONS

This jet incorporates a bayonet locking system, Twist the jet face in an anticlockwise direction and the complete one piece jet assembly will unlock and ramp out of the retainer.

MATERIAL SAFETY DATA

There are no known hazards with this product. Always insure correct installation procedures have been followed.

FLOW RATE GRAPHS

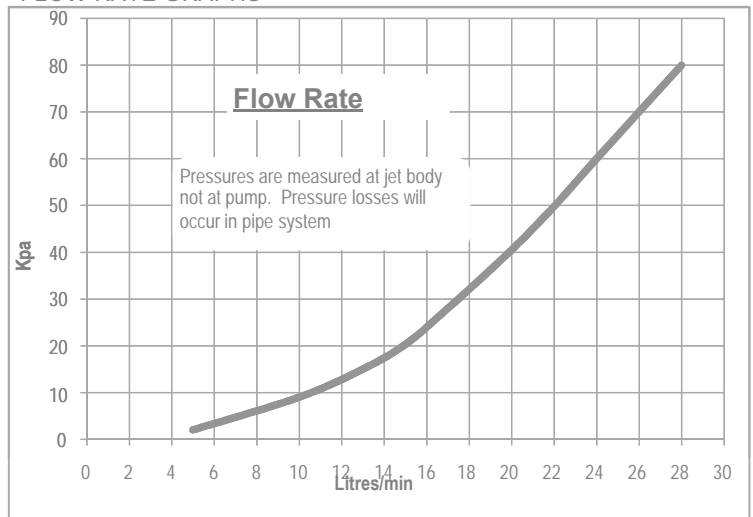

IDENTIFICATION:

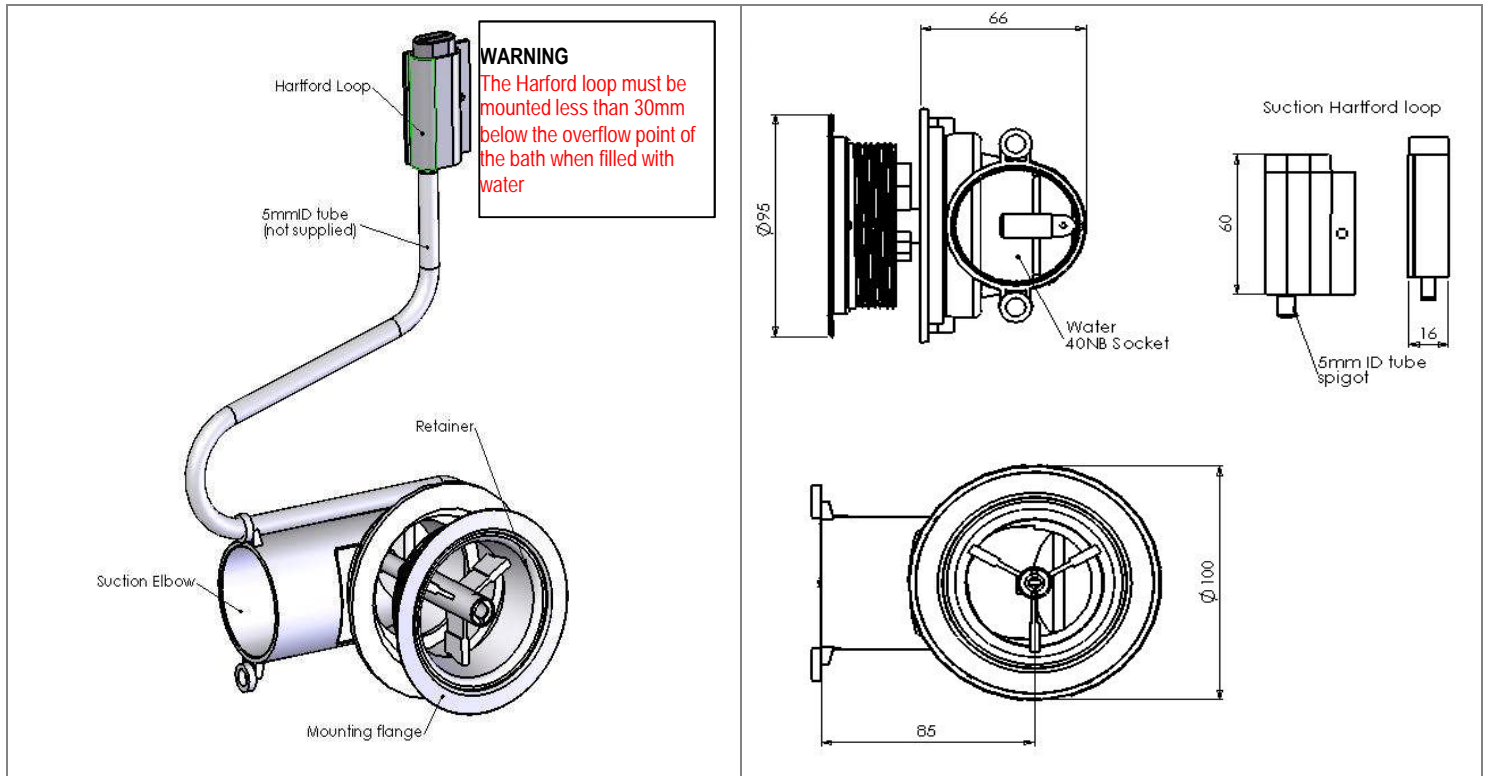

PART NUMBER	SAI1-XX
PRODUCT NAME	Suction elbow impressions 40mm

DESIGN SPECIFICATIONS

Safe flow suction elbow for use with c-lenda product range

Compact design

Protection against body and hair entrapment

Hartford loop overflow prevention device

40mm pipe flow rate

Unique safety sensing device with no moving parts

TECHNICAL SPECIFICATIONS

WATER LINE CONNECTION	40mm Pipe Socket
HARTFORD LOOP CONNECTION	5mm ID tube
MOUNTING HOLE SIZE	75 mm (3inch)
MATERIAL	R12549 Rigid PVC
COLOUR	Grey
PACKAGING	

SERVICE INSTRUCTIONS

Due to this product having no moving parts, and as long as the correct installation procedures have been followed there will be no requirement for service in the field

COMPONENT SPECIFICATIONS

Jet Body	PVC
Mounting Flange	Stainless Steel
Retainer	PVC
Hartford Loop	ABS
Connecting tube	Not Supplied

MATERIAL SAFETY DATA

When installed insure the stainless steel mounting flange sits tight to the bath wall and there are no sharp edges on the stainless steel mounting flange that could cut the user.

If the suction cover is removed all safety features will stop working!

STANDARDS

Refer to page 36 of manual for a list of standards this product is designed and manufactured to

IMPORTANT THE TOP OF THE HARTFORD LOOP MUST NOT BE MOUNTED MORE THAN 30mm BELOW THE TOP OF THE BATH FLANGE.

IDENTIFICATION:

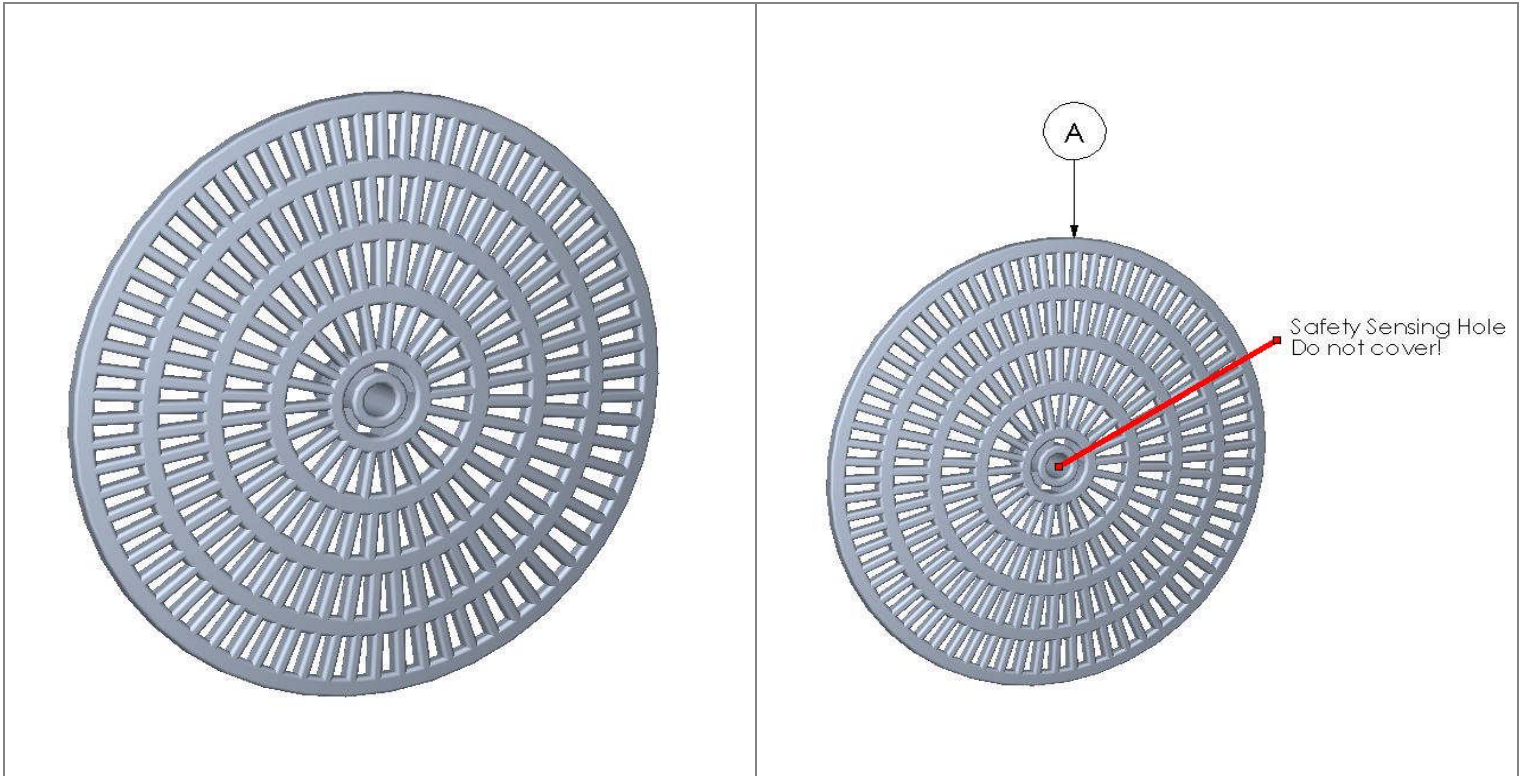

PART NUMBER	SAI1-XX
PRODUCT NAME	Suction assembly impressions

DESIGN SPECIFICATIONS

Flush Safe flow suction cover for Impressions product range

- Flush mount design
- Full 40mm pipe flow rate (tested to 400 l/min)
- Safety sensing design for hair and body entrapment
- Requires tool for removal
- Complies with AS3350

PRODUCT PART SPECIFICATIONS

ITEM	PART No	NAME	MATERIAL	FINISH
A		Suction Cover	ABS	Chrome
For chrome plate standards and finish refer to "Aesthetics Standard M01.001.002.001"				
PACKAGING				

SERVICE INSTRUCTIONS

The cover can be removed by following the instructions on instruction manual. It is recommended this is carried out by a qualified service agent. Removal of the suction cover will render the spa unsafe for use

MATERIAL SAFETY DATA

It is critical the suction cover is correctly fitted and not damaged in any way. Operating a spa without the cover fitted is not safe.

FLOW RATE

The suction has been tested to flow in excess of 400 liters / min

IDENTIFICATION:

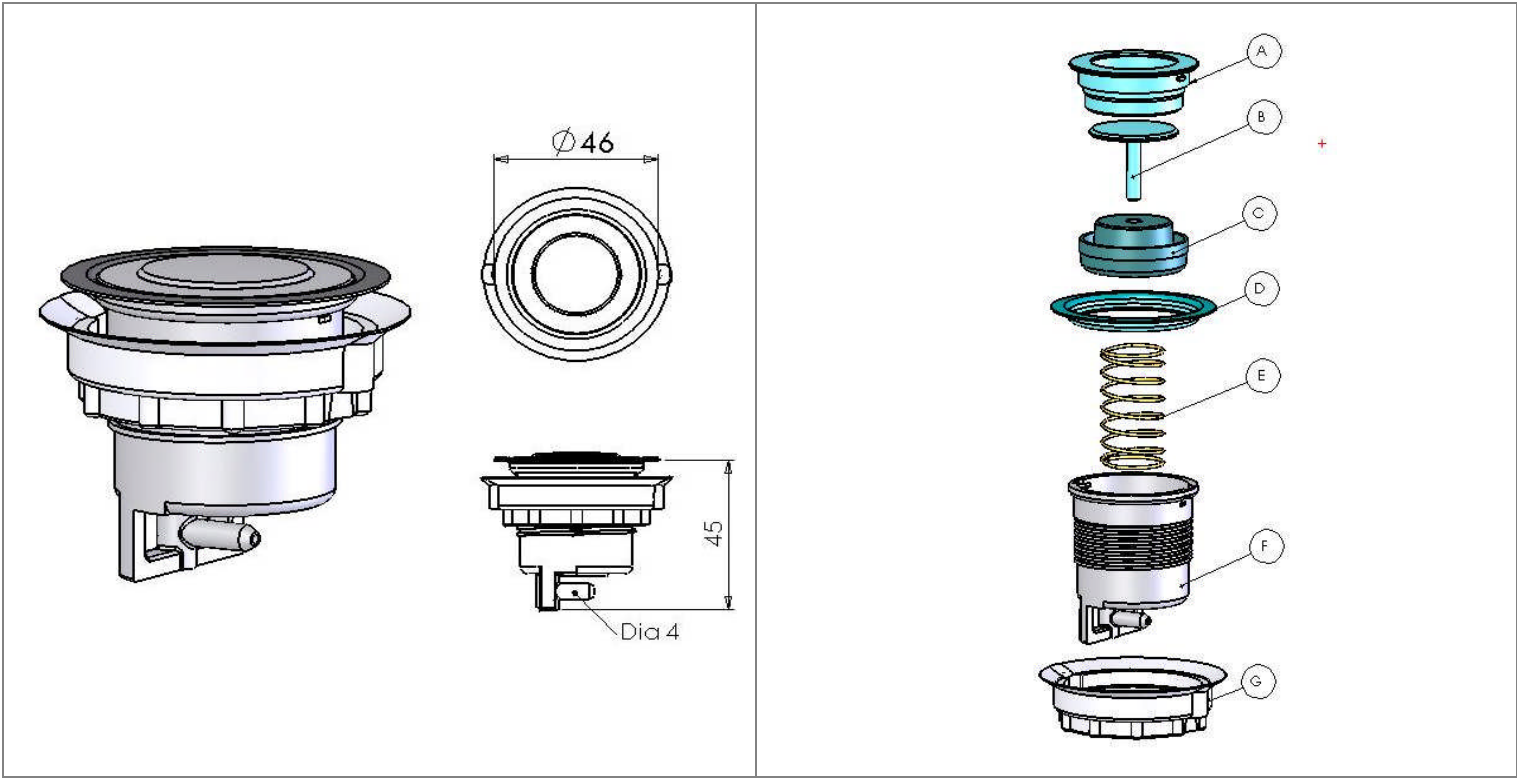

PART NUMBER	ABI-XX
PRODUCT NAME	Air button impressions

DESIGN SPECIFICATIONS

Air button, can be both a flange mount or a wall mount and operates below water level without leaking
Flush mount design
Wall or Flange mount
Operates below water level
100% watertight
Incorporates silicone injection sealing system

TECHNICAL SPECIFICATIONS

WATER LINE CONNECTION	Not applicable
AIRLINE CONNECTION	4mm Spigot
MOUNTING HOLE SIZE	38 mm (1.5 inches)
MATERIAL	R12549 Rigid PVC
COLOR	Grey
PACKAGING	

SERVICE INSTRUCTIONS

The impressions air button can be serviced from inside the bath by unlocking the trim and removing. This will allow access to the bellows and spring if required.

MATERIAL SAFETY DATA

When installed insure the stainless steel mounting flange sits tight to the bath wall and there are no sharp edges on the stainless steel mounting flange that could cut the user

PRODUCT PART SPECIFICATIONS

IDENTIFICATION:

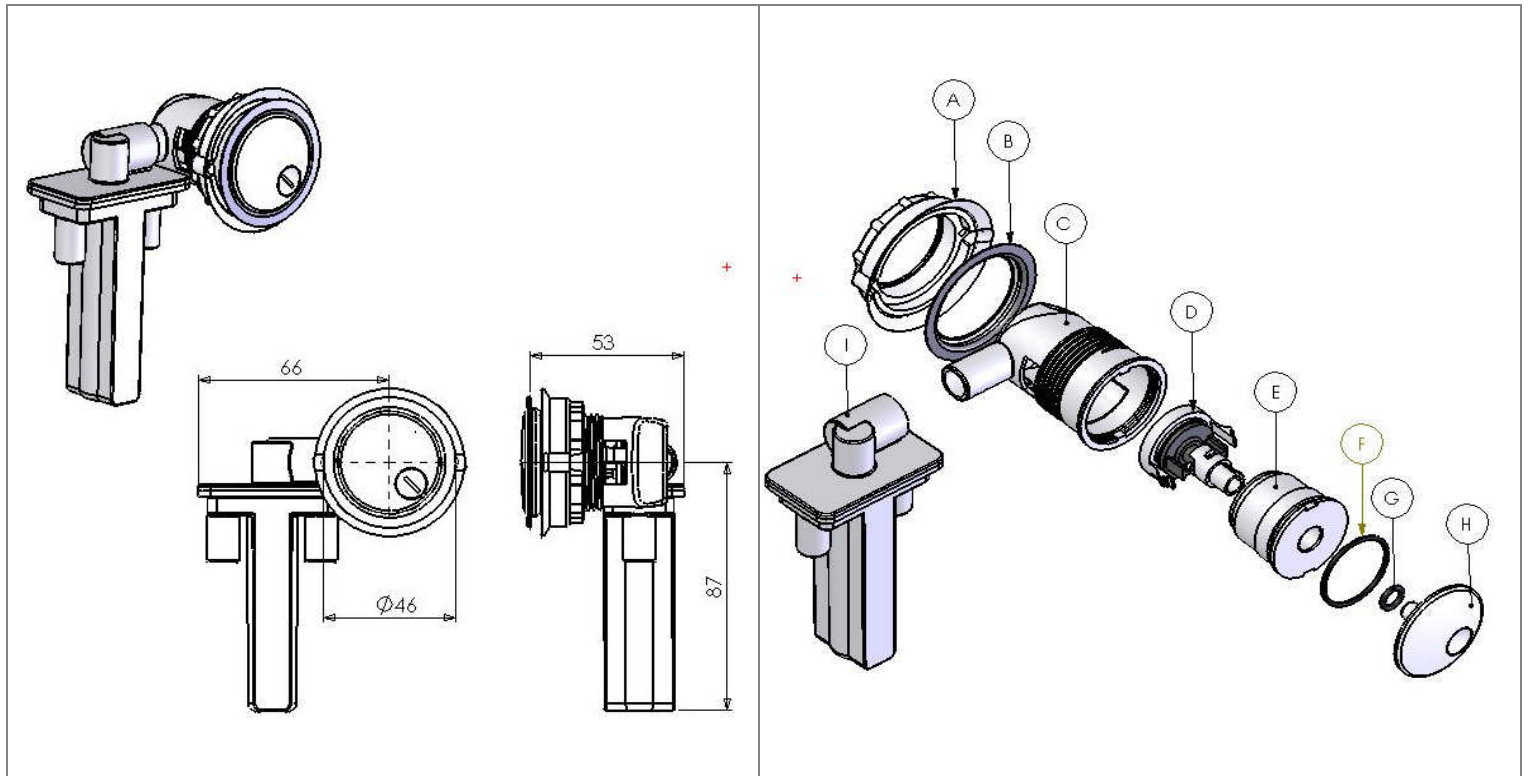

PART NUMBER	SACI-XX
PRODUCT NAME	Silent Air Control Impressions

DESIGN SPECIFICATIONS

Flush Air control for Impressions product range

- Flush mount design
- Flange or wall mount design
- Hartford loop to allow below level water mounting
- Easy to turn
- High air flow

SERVICE INSTRUCTIONS

The c-lenda air control can be serviced from inside the bath by removing the cap and lifting out the oring support. This will allow access to the inside components of the product

MATERIAL SAFETY DATA

When installed insure the stainless steel mounting flange sits tight to the bath wall and there are no sharp edges on the stainless steel mounting flange that could cut the user

DO NOT MOUNT THE AIR CONTROL MORE THAN THE MAXIMUM RECOMMENDED DISTANCE BELOW THE BATH FLANGE

TECHNICAL SPECIFICATIONS

WATER LINE CONNECTION	Not applicable
AIRLINE CONNECTION	10NB Spigot
MOUNTING HOLE SIZE	38mm (1.5 inches)
MATERIAL	R12549 Rigid PVC
COLOR	Grey
PACKAGING	

THE MAXIMUM MOUNTING DISTANCE FROM THE OVERFLOW POINT OF THE BATH FLANGE DOWNTWO THE CENTRE OF THE AIRCONTROL ON A WALL MOUNT INSTALLTION IS 65MM

PRODUCT PART SPECIFICATIONS

ITEM	PART No	NAME	MATERIAL	FINISH

Impressions

**INSTALL
&
SERVICE
INSTRUCTIONS**

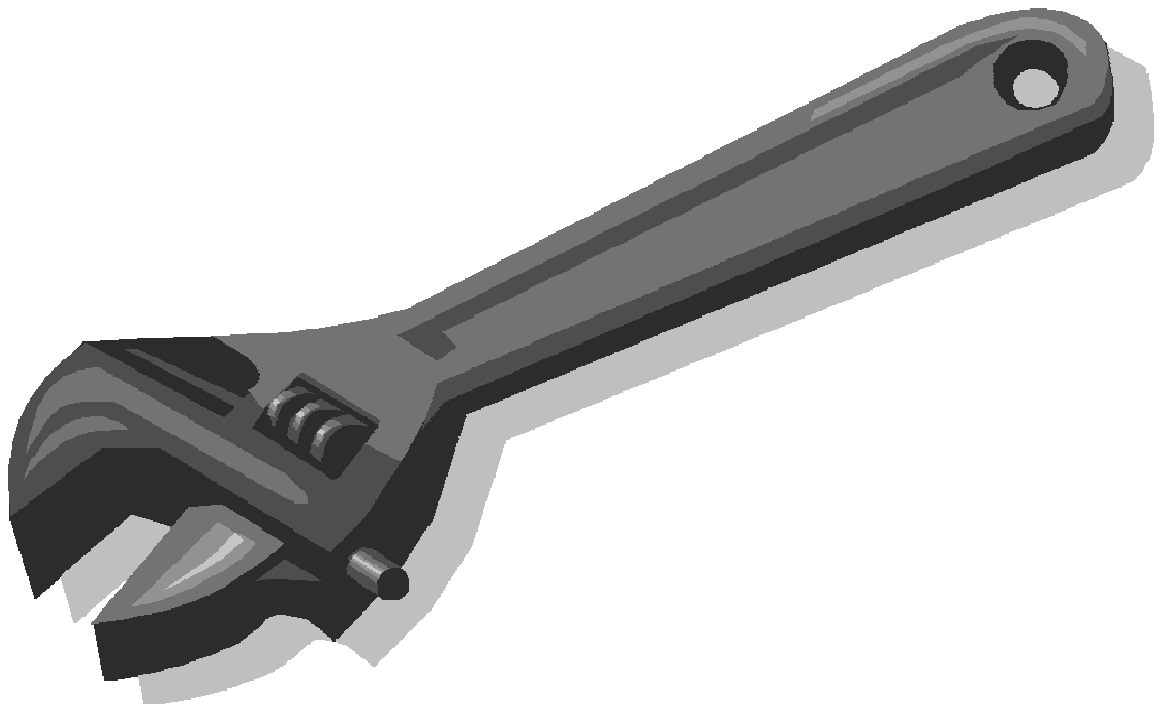

The following instructions are intended as a guide and check list only. If the plumber assembling these products has better methods that ensure a quicker and safer installation then use those methods over these providing it is not to the detriment of the product.

TOOLS REQUIRED

- √ Tool Part No 500109
- √ Silicone Sealant
- √ 2 inch Hole Saw (50mm)
- √ Drill
- √ Deburring Tool

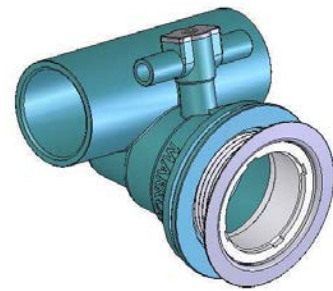

INSTALLATION METHOD



Drill hole through bath wall using 2 inch hole saw



THERE MUST BE NO BURR ON EDGE OF HOLE, a burr could stop the mounting flange sitting down flush



Apply an adequate amount of silicone to front flange of body



Locate flange and stainless steel mounting flange into hole in bath



Using Installation Tool screw retainer into jet body. Hand tighten only. **DO NOT OVERTIGHTEN**



CHECK THAT THE EDGE OF THE MOUNTING FLANGE IS PULLED DOWN AND THERE ARE NO SHARP EDGES



Glue 25 pressure pipe into sockets



Glue and fit airline



Clamp airline

CHECK LIST

- √ Did I apply enough silicone in a continuous bead around the body flange?
- √ Did I clean the edge of the hole to ensure no up stand could prevent the mounting flange sitting flat?
- √ Did I tighten the retainer enough?
- √ Is the stainless steel flange pulled down hard all around its edge?
- √ Are there sharp edges on the stainless steel mounting flange that could cut somebody?

INSTALLATION INSTRUCTIONS

MJI1-XX

impressions directional jet

The following instructions are intended as a guide and check list only. If the plumber assembling these products has better methods that ensure a quicker and safer installation then use those methods over these providing it is not to the detriment of the product.

TOOLS REQUIRED

- √ Service Tool, Part No MT0268
(for removal only)

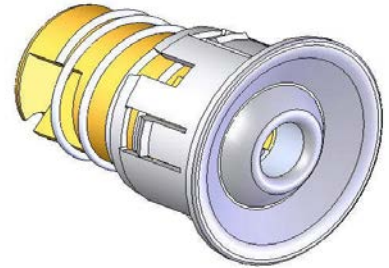

INSTALLATION METHOD

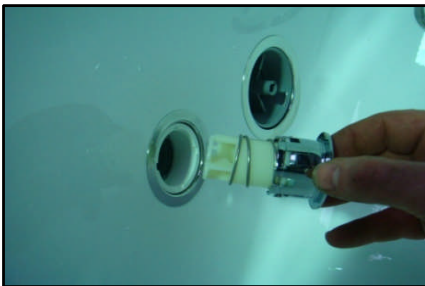

Push jet into body 25x10



Insure Jet clips fully home and locked in place,
CHECK EYEBALL IS NOT LOOSE



Check action of eyeball by pivoting from side to side. Should be smooth action, not loose.

REMOVAL FOR CLEANING OR SERVICE



Using Service Tool MT0268, push eyeball back and clip tool under edge of jet face.



Pull out with a firm action.
Remove tool from centre of jet face

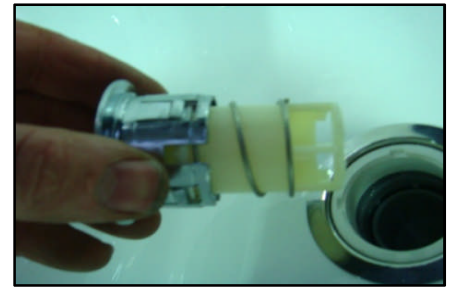

Clean Jet, check spring ok and there are no broken parts, replace as above procedure.

CHECK LIST

- √ Is the spring on the jet assembly?
- √ Is the jet locked fully in place?
- √ Does the jet sit flush in the mounting flange?
- √ Does the eyeball have spring tension on it so it pivots with a firm action?
- √ Are there sharp edges on the stainless steel mounting flange that could cut somebody?

The following instructions are intended as a guide and check list only. If the plumber assembling these products has better methods that ensure a quicker and safer installation then use those methods over these providing it is not to the detriment of the product.

TOOLS REQUIRED

- installation Tool, Part No 500109
- Silicone Sealant
- 1.5 inch Hole Saw (38mm)
- Drill
- Deburring Tool



INSTALLATION METHOD



Drill hole through bath wall using 1.5 inch hole saw



THERE MUST BE NO BURR ON EDGE OF HOLE, a burr could stop the mounting flange sitting down flush



Apply an adequate amount of silicone to front flange of body



Locate retainer and mounting flange into hole in bath



Using Installation tool screw retainer into jet body. Hand tighten only DO NOT OVERTIGHTEN

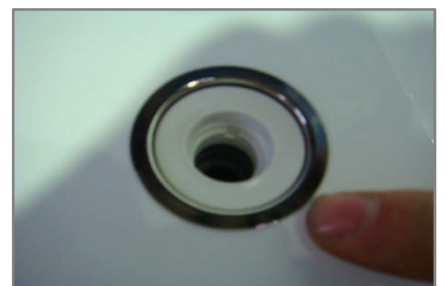

CHECK THAT THE EDGE OF THE MOUNTING FLANGE IS PULLED DOWN AND THERE IS NO SHARP EDGE



Glue and fit airline



Push 19mm flex pipe on barb spigot.



Fit clamping clip to retain pipe

CHECK LIST

- ✓ Did I apply enough silicone in a continuous bead around the body flange?
- ✓ Did I clean the edge of the hole to ensure no up stand could prevent the mounting flange sitting flat?
- ✓ Did I tighten the retainer enough?
- ✓ Is the stainless steel mounting flange pulled down hard all around its edge?
- ✓ Are there sharp edges on the stainless steel mounting flange that could cut somebody?

The following instructions are intended as a guide and check list only. If the plumber assembling these products has better methods that ensure a quicker and safer installation then use those methods over these providing it is not to the detriment of the product.

TOOLS REQUIRED

Installation Tool, Part No 500109

Silicone Sealant

√ 2.75 inch Hole Saw (70mm)

√ Drill

√ Deburring Tool

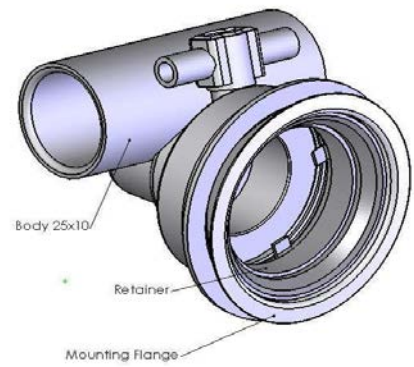

INSTALLATION METHOD



Drill hole through bath wall using 1.5 inch hole saw



THERE MUST BE NO BURR ON EDGE OF HOLE, a burr could stop the mounting flange sitting down flush



Apply an adequate amount of silicone to front flange of body



Locate retainer and mounting flange into hole in bath



Using Installation tool screw retainer into jet body. Hand tighten only DO NOT OVERTIGHTEN



CHECK THAT THE EDGE OF THE MOUNTING FLANGE IS PULLED DOWN AND THERE IS NO SHARP EDGE



Push 19mm flex pipe on barb spigot.



Fit clamping clip to retain pipe

CHECK LIST

- √ Did I apply enough silicone in a continuous bead around the body flange?
- √ Did I clean the edge of the hole to ensure no up stand could prevent the mounting flange sitting flat?
- √ Did I tighten the retainer enough?
- √ Is the stainless steel flange pulled down hard all around its edge?
- √ Are there sharp edges on the stainless steel mounting flange that could cut somebody?

The following instructions are intended as a guide and check list only. If the plumber assembling these products has better methods that ensure a quicker and safer installation then use those methods over these providing it is not to the detriment of the product.

TOOLS REQUIRED

- √ Installation Tool, Part No 500109

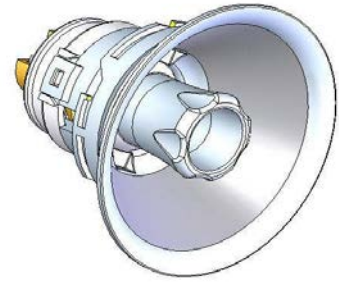

INSTALLATION METHOD



Push Jet into Jet Body



Using Installation tool MT0168 rotate in clockwise direction, a clipping action indicates jet is locked in place



Check jet is sitting flush with mounting flange.

REMOVAL FOR CLEANING OR SERVICE



Using Installation Tool 500109 insert drive legs in slots at bottom of jet and rotate anticlockwise



Jet will unlock and ramp out of retainer and become free to remove.

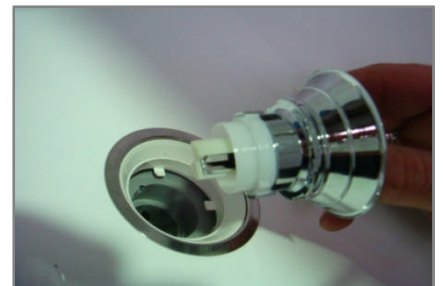

Clean Jet, check there are no broken parts, replace as per above procedure.

CHECK LIST

- √ Is the jet locked fully in place?
- √ Is the jet flush with the mounting flange?
- √ Is the nozzle easy to twist to adjust flow?
- √ Does the nozzle pivot from side to side with a smooth action?
- √ Are there sharp edges on the mounting flange that could cut somebody?

The following instructions are intended as a guide and check list only. If the plumber assembling these products has better methods that ensure a quicker and safer installation then use those methods over these providing it is not to the detriment of the product.

TOOLS REQUIRED

- ✓ Tool, Part No 500109
- ✓ Silicone Sealant
- ✓ 3 inch Hole Saw (75mm)
- ✓ Drill
- ✓ Deburring tool

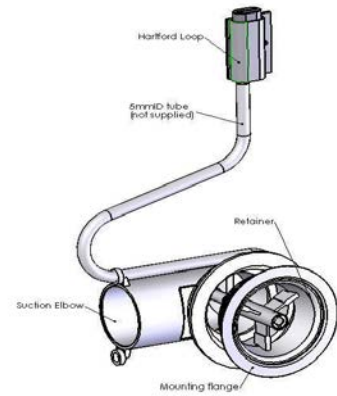

INSTALLATION METHOD



Drill hole through bath wall using 3 inch hole saw

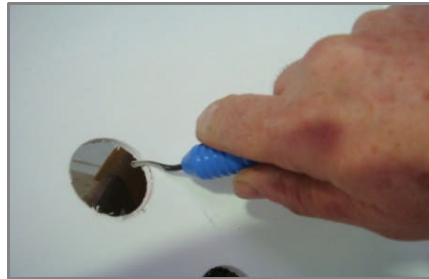

THERE MUST BE NO BURR ON EDGE OF HOLE, a burr could stop the mounting flange sitting down flush



Apply an adequate amount of silicone to front flange of body

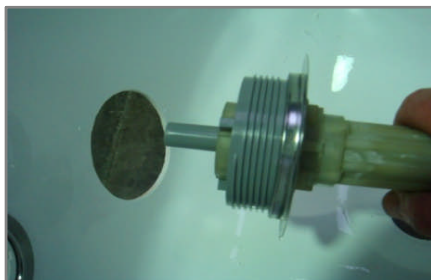

Locate locking flange and stainless steel trim into hole in bath



Using Tool MT0168 tighten retainer into elbow. Max torque 14nm



CHECK THAT THE EDGE OF THE MOUNTING FLANGE IS PULLED DOWN AND THERE IS NO SHARP EDGE

THE HARTFORD LOOP UNIT MUST BE MOUNTED LESS THAN 30MM BELOW THE OVERFLOW POINT OF BATH



Stick Hartford loop less than 30mm from the top of the bath rim.
SEE MAX DISTANCE ON SPEC SHEET.



Apply silicone bead to each side of Hartford loop to ensure component sticks to bath permanently.



Glue and fit 5mm ID tube as shown feeding through retaining lugs to prevent accidental removal.

CHECK LIST

- ✓ Did I clean the edge of the hole to ensure no up stand could prevent the mounting flange sitting flat?
- ✓ Did I tighten the retainer correctly?
- ✓ Is the mounting flange pulled down all around its edge?
- ✓ Was the dust wiped off the bath wall before sticking the Hartford loop to it?
- ✓ THE TOP OF THE HARTFORD LOOP IS LESS THAN 30MM BELOW THE TOP OF THE BATH FLANGE.
- ✓ Have I applied a silicone bead to each side of the Hartford loop to prevent it coming off?
- ✓ MAKE SURE THE CONNECTING TUBE IS SECURED CORRECTLY. IT MUST NOT BE ABLE TO BE REMOVED.
- ✓ Are there sharp edges on the stainless steel mounting flange that could cut somebody?

INSTALLATION INSTRUCTIONS

Suction Safe flow impressions

The following instructions are intended as a guide and check list only. If the plumber assembling these products has better methods that ensure a quicker and safer installation then use those methods over these providing it is not to the detriment of the product.

TOOLS REQUIRED

- √ Self Tapping screw
- √ Pliers



INSTALLATION METHOD



Locate spigot on back of cover into hole in retainer centre.



Push firmly and snap into place.



DO NOT cover the safety sensing centre hole with a label or anything else.

REMOVAL FOR REPLACEMENT



Screw the self tapping screw in the centre hole approx 3 turns



Grip firmly with pliers and pull cover off.



Replace as above checking the centre hole is not damaged or blocked.

CHECK LIST

- √ Is the cover locked fully in place?
- √ Can I lift it by the edge of the cover?
- √ Does the cover sit flush with the stainless steel mounting flange?
- √ The safety sensing hole has not been covered with anything?
- √ Are there sharp edges on the stainless steel mounting flange that could cut somebody?

The following instructions are intended as a guide and check list only. If the plumber assembling these products has better methods that ensure a quicker and safer installation then use those methods over these providing it is not to the detriment of the product.

TOOLS REQUIRED

- ✓ 1.5 inch Hole Saw (38mm)
- ✓ Silicone Sealant
- ✓ Drill
- ✓ Deburring Tool

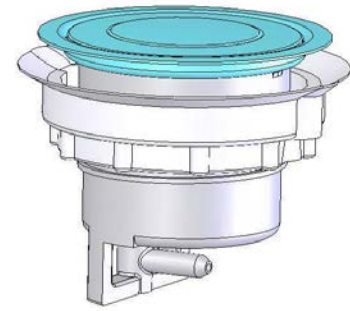

INSTALLATION METHOD



Drill hole through bath wall using 1.5 inch hole saw



Remove any burr on top edge of hole with deburring tool. A burr could prevent stainless flange sitting flush.



Remove nut from body and pass body through hole.



Refit nut and hand tighten, pulling the conical flange on the nut down onto the bath wall



Inject silicone through one of the injection holes in the nut until it oozes out the opposite hole.



Loop the airline tube through the windows at the bottom and fit to the spigot to prevent it being pulled off.

SERVICE



Unclip the air button trim as by twisting in anticlockwise direction as shown



Remove trim and plunger, allowing access to bellows and spring.



Inspect and replace if required.

CHECK LIST

- ✓ Did I clean the edge of the hole to ensure no upstand that could prevent the mounting flange sitting flat?
- ✓ Did I tighten the nut correctly?
- ✓ Did I inject the silicone correctly so it oozed out the opposite hole?
- ✓ Is the mounting flange pulled down all around its edge?
- ✓ Are there sharp edges on the stainless steel mounting flange that could cut somebody?

INSTALLATION INSTRUCTIONS SACI-XX

Silent Air Control Impressions

The following instructions are intended as a guide and check list only. If the plumber assembling these products has better methods that ensure a quicker and safer installation then use those methods over these providing it is not to the detriment of the product.

TOOLS REQUIRED

- √ 1.5 inch Hole Saw (38mm)
- √ Silicone Sealant
- √ Drill
- √ Deburring Tool
- √ Solvent cement

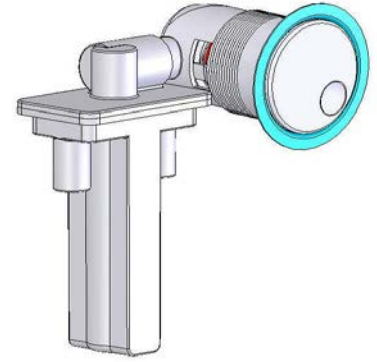

INSTALLATION METHOD



Drill hole through bath wall using 1.5 inch hole saw



Remove any burr on top edge of hole with deburring tool. A burr could prevent stainless flange sitting flush.



Remove nut from body and pass body through hole in bath.



Refit nut and hand tighten, pulling the conical flange on the nut down onto the bath wall.



Inject silicone through one of the injection holes in the nut until it oozes out the opposite hole.



Glue Hartford loop onto spigot, positioning Hartford loop in as close to vertical position as possible

SERVICE METHOD



Remove cap by lifting under edge as shown.



Pick out centre piece as shown. Internal components can now be accessed for servicing.



Inspect and replace if required, re-assemble unit

CHECK LIST

- √ Is the Hartford loop glued in place in a near vertical position.
- √ Did I clean the edge of the hole to ensure no up stand that could prevent the mounting flange sitting flat?
- √ Did I tighten the nut correctly?
- √ Did I inject the silicone correctly so it oozed out the opposite hole?
- √ Is the mounting flange pulled down all around its edge?
- √ Are there sharp edges on the stainless steel mounting flange that could cut somebody?

The MT1068 is a multi-purpose tool designed to minimize the amount of different tools the installer is required to carry. Made of a strong glass filled nylon the tool has tensile strengths equivalent to aluminum with none of the associated problems than can occur by dropping tools in a bath.

The 2 piece tool has a head that can be removed and turned around to accommodate other products. Likewise the handle can be used on its own and is used as a tool for installing jet assemblies into bodies. See details below for identification of which end to use with the impressions products.

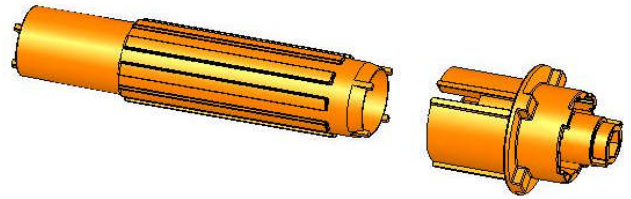

IDENTIFICATION

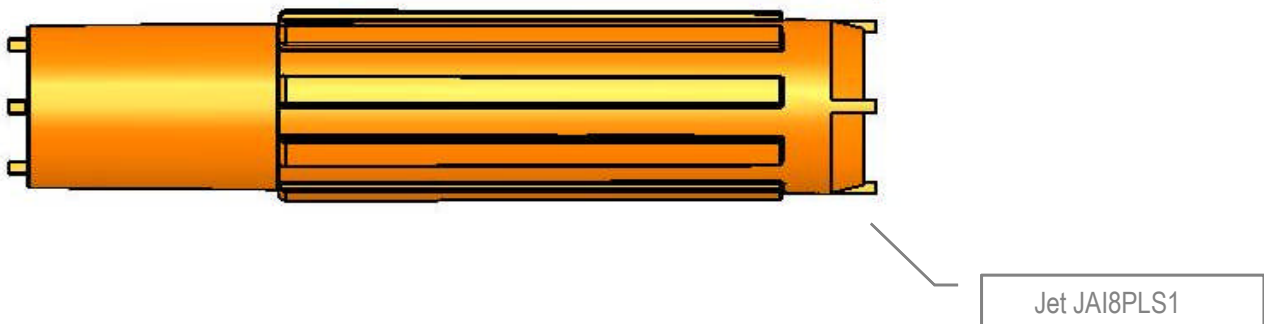
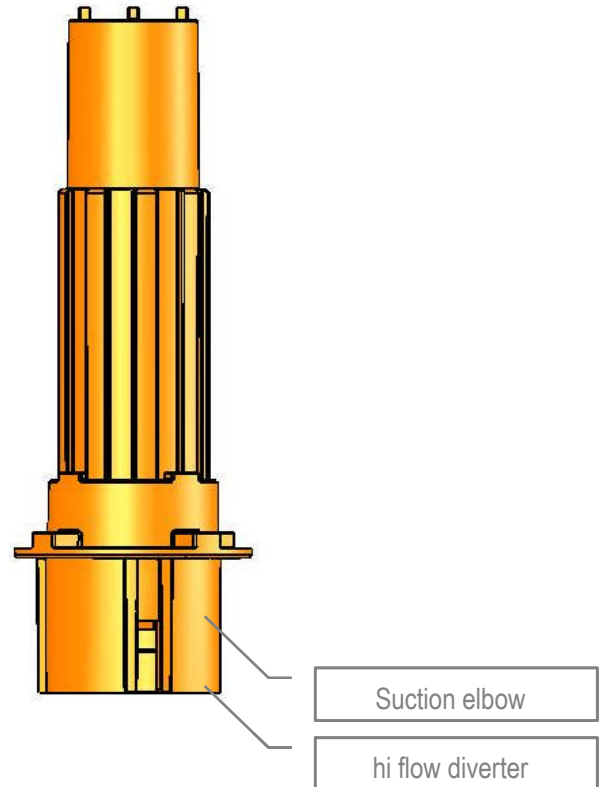
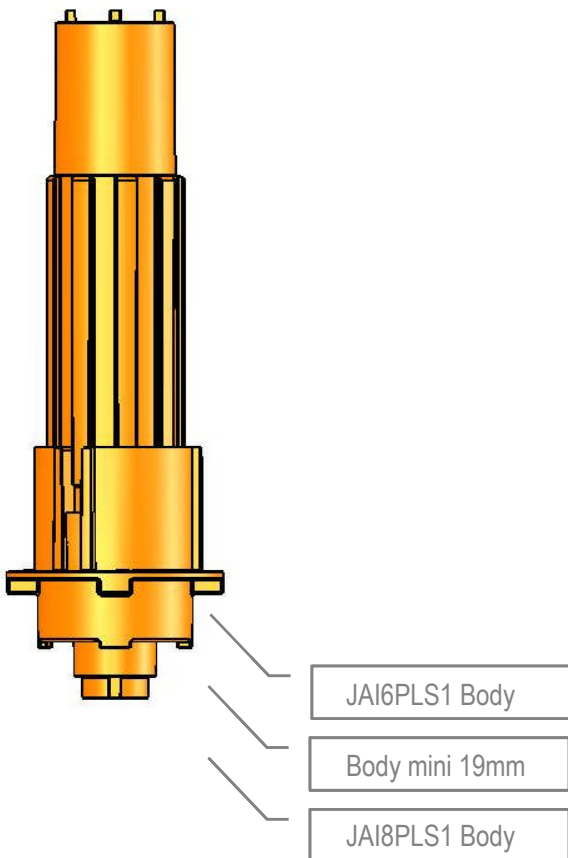

HOW A HARTFORD LOOP WORKS

A Hartford loop is a device used to prevent under-the-rim fittings connected to air lines from overflowing and leaking behind the bath when it is overfilled. Below is a brief outline of how the Hartford loop achieves this.

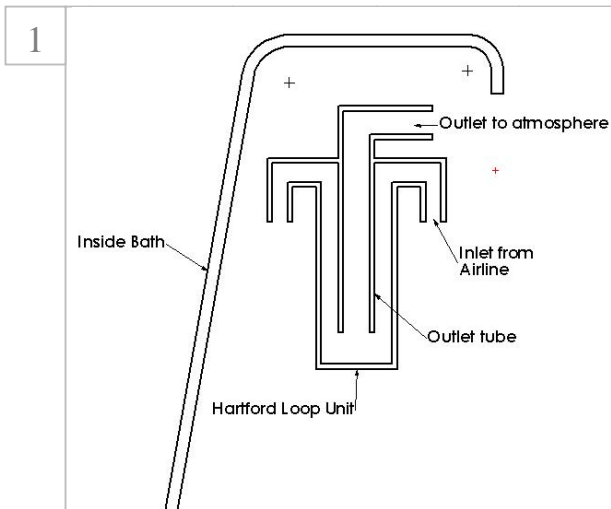

The Hartford loop must be mounted as close to the underside of the flange as possible. There is a maximum distance that it can be mounted below the flange. Refer to the specification sheets for the specific product details.

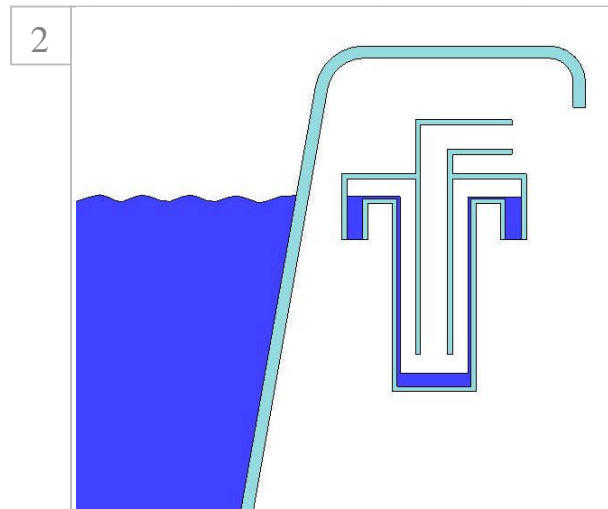

As the water level in the bath rises water flows up the airlines to the same level. Eventually the water spills over the lip of the inlet spigot to start filling the body of the fitting.

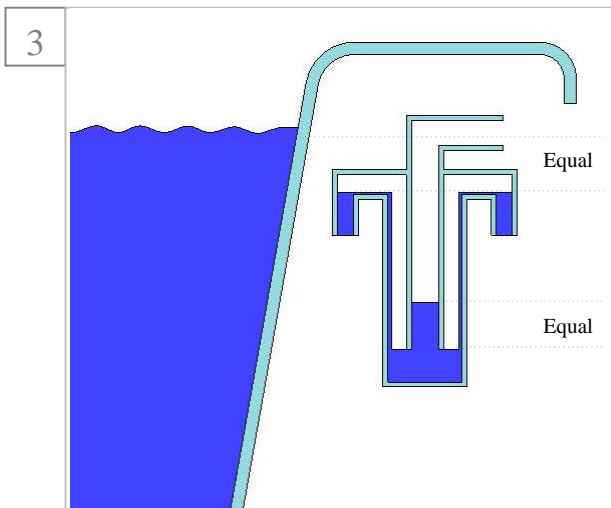

Once the level of the water in the fitting reaches the bottom of the outlet tube it creates a seal, trapping air in the body. As the bath water level rises further the water rises a similar amount in the outlet tube.

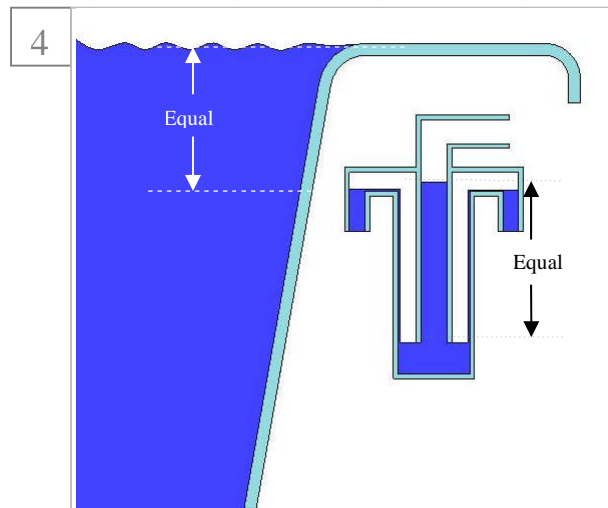

When the bath is full to overflowing the water has risen to a point in the tube that is below the outlet level so it will not drain onto the floor under the bath. If the fitting has been installed too far beneath the bath rim the water will rise to the level of the outlet and drain onto the floor.

When emptying the bath or operating the jets the water is sucked out of the body of the fitting.

Ideally a Hartford loop should be positioned as close to vertical as possible. NuWhirl has tested the units to work at a slope of 25 degrees each side of vertical.

HOW A SAFE-FLO SUCTION WORKS

The safe-flo suction prevents both body and hair entrapment by using a unique sensing device that introduces air into the pump stopping the suction pressure within seconds of being activated.

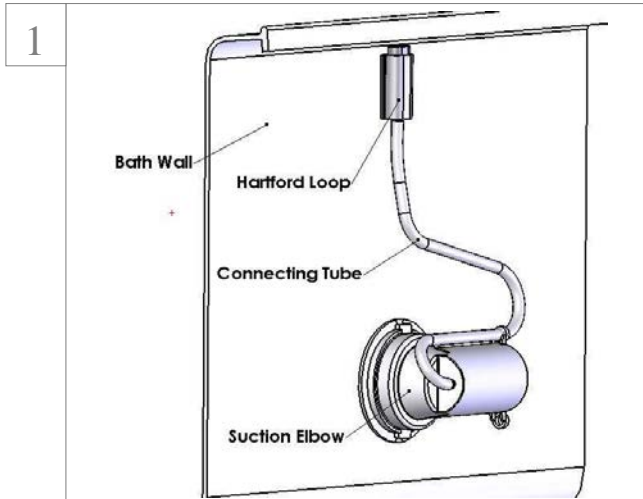

The suction assembly is mounted as shown above. A 5mm ID tube connects to a Hartford loop mounted up close to the underside of the bath flange.

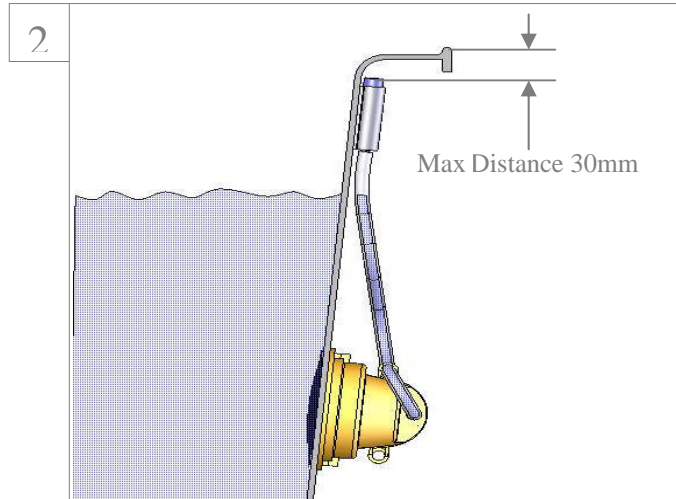

When the bath is filled with water the tube the 5mm ID tube from the suction also fills with water. The Hartford loop prevents the water from spilling out the top of the tube should the bath be overfilled.

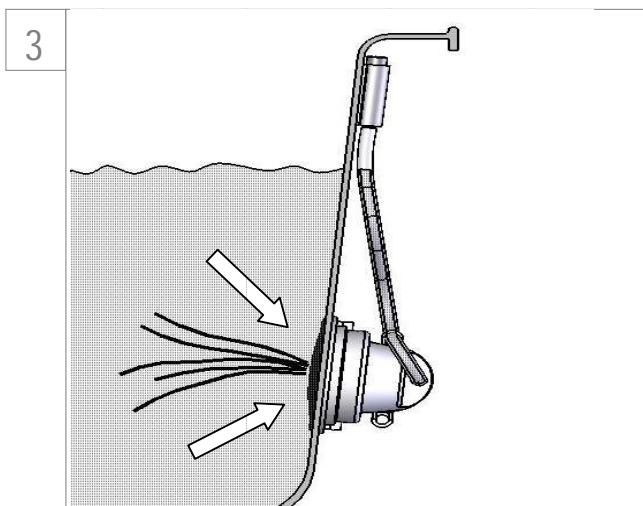

When the pump is running and long hair comes in near contact with the suction cover it is drawn towards the centre of the cover, restricting the small safety sensing hole in the centre.

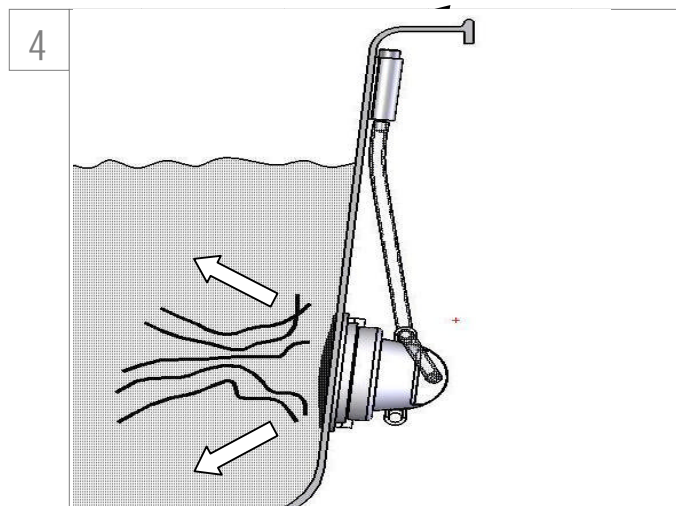

When this hole becomes restricted a venturi effect is created within the suction elbow, creating suction down the 5mm tube. Air is quickly drawn into the suction line causing the pump to cavitate and stop pumping, allowing the hair to be easily pulled away. Once clear the air stops getting drawn into the pump allowing the flow to start up again.

STANDARDS and MATERIAL SPECIFICATIONS

The Impressions range of spa bath fittings are designed and manufactured in accordance with the following standards.

Products

Jet bodies and fittings	AS1477
Suctions	AS3350 ASME A112.18.1M

Material Specifications

Rigid PVC	Grade Type Hardness (ASTM D2240 shore@ 23degC) Specific Gravity (ASTM D792) Tensile Strength (ASTM D412) Vicat Softening Pt <i>Designed to meet pressure pipe requirements of AS1477</i>	R12549 Calcium / Zinc D80 1.42 36 MPa 79.0deg °C
ABS	Grade Type Hardness (D-785) Specific Gravity (D-792) Tensile Strength (D-638) Vicat Softening Point (D-1525)	PA727 Electroplating R-110 1.04 48.5 MPa 105deg °C
Stainless Steel	Grade Finish(seen face)	304 BA Polished

Finishes

Electroplating Surfaces	ASTASTM B 604 Aesthetics Standard	M01.001.002.001
----------------------------	--------------------------------------	-----------------

Impressions

Summary of Critical Checks

- The mounting flanges are pulled down against the bath wall and will not present an edge that could cut somebody
- The Hartford loops and associated fittings are mounted at the correct height from the bath rim so that water cannot leak behind the bath.
- The retainers in the jets are correctly tightened
- An adequate amount of silicone is applied to the jet bodies so that they will seal correctly to the bath wall and not leak.
- The silicone injection nuts on the air button and air control have the silicone injected into them so that it oozes out the opposite hole ensuring a full seal.
- The jets and seen fitting are sitting flush with the mounting flange.
- The connecting tube on the air button and suction elbow are secured out of the way to prevent accidental removal when handling the bath
- Air lines are clamped to the top of the water lines in a manner that prevents the airline sagging and retaining water.
- The clamping rings are fitted to the 19mm flex tubing connections.
- The jets and fittings function as intended

Impressions

Notes
